

INSTALLER! PLEASE LEAVE WITH HOMEOWNER



INSTALLATION AND OPERATING INSTRUCTIONS "BIG TEX" VENTED GAS LOGS

by *Golden Blount*

Please Note: It is important that you read instructions before installing or operating gas logs

GENERAL INFORMATION

Gas logs are to be burned only in approved woodburning Fireplace with adequate chimney draft. When burning, the chimney damper must be FULLY OPEN. Log set must be installed in fireplace which operates properly when wood fires are burned.

- For best results, natural gas pressure must be 7" to 10-1/2" water column.
- To simulate real wood burning, the gas burner is designed to burn a yellow flame. It is normal for the logs to soot-up. The soot can easily be removed with a vacuum cleaner or a soft brush.
- A fireplace screen must be in place when the appliance is operating and, unless other provisions for combustion air are provided, the screen shall have an opening (s) for introduction of combustion air.
- If used with glass fireplace doors, burn with doors in open position.
- Do not burn wood or other items with log set.

FOR YOUR SAFETY

If you smell gas:

1. Open Windows.
2. Don't Touch electrical switches.
3. Extinguish any open flame.
4. Immediately call your gas supplier.

FOR YOUR SAFETY

Do not store or use gasoline or other flammable vapors and liquids in the vicinity of this or any other appliance.

IMPORTANT INFORMATION

CHECK TO BE SURE LOG SET IS FOR PROPER GAS TYPE

Log sets are designed for use with Natural Gas, unless clearly labeled for Propane (LP). Never use Propane Gas in a log set designed for Natural Gas, or Natural Gas in a log set designed for use with Propane Gas.

The installation, including provisions for combustion and ventilation air, must conform with local codes or, in the absence of local codes, with the national fuel Gas Code, ANSI Z223.1-1988 and NFPA54-1988.

The appliance and its individual shutoff valve must be disconnected from the gas supply piping system when testing at test pressures in excess of 1/2 psig.

The appliance must be isolated from the gas supply piping system by closing its individual manual shutoff valve during any pressure testing of gas-supply system at test pressures equal to or less than 1/2 psig. This is accomplished by closing the gas supply line valve, which is required by NFPA 54, section 5.54.

The minimum inlet gas supply pressure for the purpose of input adjustment is 7" WC for Natural Gas and 11" WC for Propane Gas.

The maximum inlet gas supply pressure for this burner is 10.5" for Natural Gas and 13" for Propane Gas.

IMPORTANT: MINIMUM SPECIFICATIONS LISTED IN THE CHART ON PAGE 2 OF THESE INSTRUCTIONS MUST BE MET TO SAFELY INSTALL AND OPERATE THIS GAS LOG SET.

"BIG TEX" SPECIFICATIONS

MODEL #	MINIMUM REQUIRED WIDTH	MINIMUM REQUIRED DEPTH	SEE-THRU MINIMUM DEPTH	OVERALL HEIGHT WITH LOGS	MINIMUM REQUIRED BTU	MINIMUM REQUIRED GAS PIPING
BT24	34"	20"	24"	18"	80,000	1/2" I.D.
BT30	40"	20"	28"	18"	90,000	1/2" I.D.
BT36	46"	22"	28"	20"	120,000	1/2" I.D.
BT42	52"	22"	28"	24"	140,000	3/4" I.D.
BT48	58"	22"	28"	24"	160,000	3/4" I.D.
BT60	70"	22"	28"	24"	180,000	1" I.D.
BT72	82"	22"	28"	24"	220,000	1" I.D.

Components Parts

ITEM

1. 2-Stage Burner Assembly
2. Silica Sand (Used in raised rear burner – Nat. Gas)
3. Glowing Embers
4. Black Volcanic Cinders
5. Vermiculite (Used in raised rear burner – LP Gas and used on top of lower adjustable burner – Nat. & LP Gas)
6. Gas Connector
7. Damper Clamp
8. Control Tool (Adjustable lower burner)

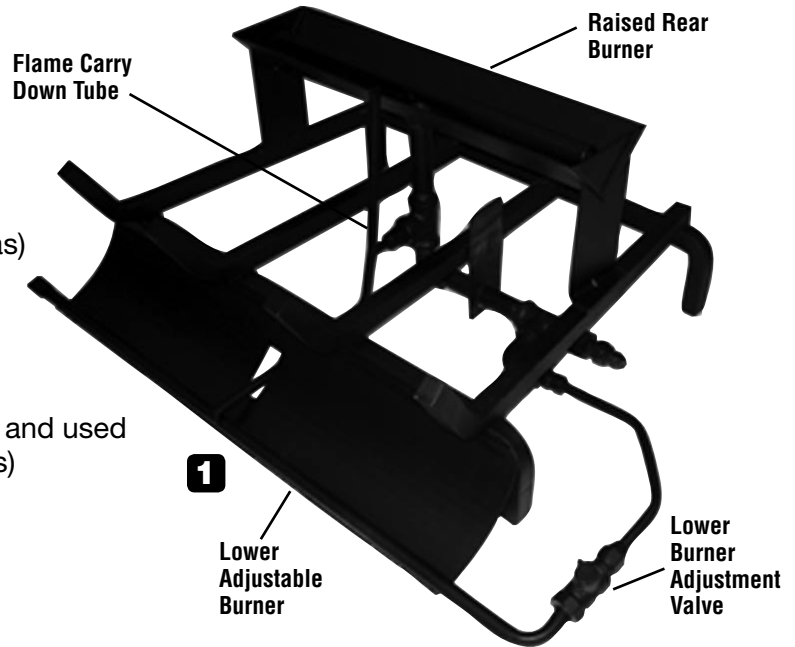

NOTE: "Big Tex" ceramic gas logs are packaged in separate cartons. Individual logs and log arrangement instructions are supplied in log cartons.

*The gas fittings supplied are for what the factory considers a normal installation. Some installations may require a longer connector tube or other fittings available in most hardware stores.



L.P. SETS MUST INCLUDE GB FACTORY INSTALLED SAFETY PILOT KIT

To Install Gas Log Set:

1. Attach damper clamp to fireplace damper to prevent damper from being fully closed.
2. Position burner assembly into fireplace and position in center and as far toward the rear as possible (See "Big Tex" Specifications for allowable dimensions).
3. Attach aluminum connector to gas supply line and connect to burner assembly. Use soapy water to check connections for leaks.
4. Pour silica sand into raised rear burner completely covering pipe in pan. For LP Gas models, use vermiculite instead of sand. (Figure 3-1)
5. Place glowing ember material over sand (vermiculite LP). (Figure 3-2)
6. Pour vermiculite over lower adjustable burner. (Figure 3-3)
7. Place glowing ember material over vermiculite and upward covering sheet metal deflector. (Figure 3-4)
8. Spread the black volcanic cinders in front of and on sides of adjustable lower burner. (Figure 3-5)
9. Position bottom front log on grate. Front log position should be as forward as possible to allow proper space for flame carry down tube. (Figure 3-6)
10. Position rest of logs on grate using log arrangement sheet supplied with logs.

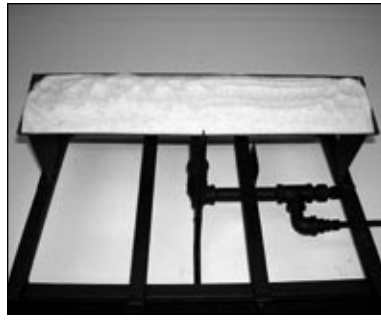

Figure 3-1

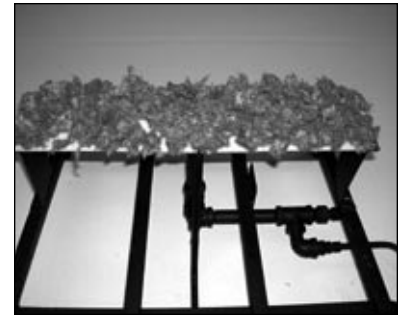

Figure 3-2

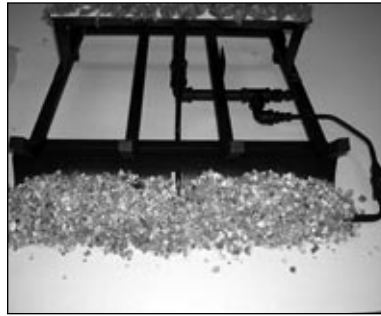

Figure 3-3



Figure 3-4



Figure 3-5

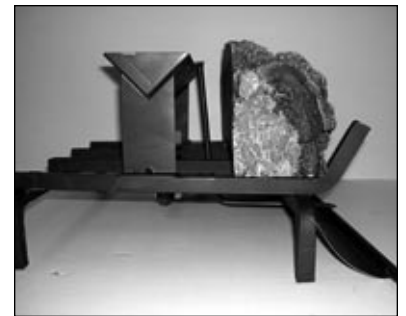

Figure 3-6

**IMPORTANT – PLEASE NOTE L.P. GAS MODELS!
MODERATE SOOT ACCUMULATION IS CONSIDERED
NORMAL FOR L.P. GAS LOGS.**

**DAMPER MUST BE IN FULL OPEN POSITION
BEFORE LIGHTING**

**LIGHTING INSTRUCTIONS FOR
"BIG TEX" MODELS SUPPLIED WITH
3 IN 1 GAS CONTROL VALVE OR HIGH
OUTPUT MILLIVOLT CONTROL VALVE
ARE LOCATED ON PAGE 4 OF THESE
INSTRUCTIONS.**

YOU ARE NOW READY TO LIGHT THE LOG SET BY TURNING THE FIREPLACE GAS VALVE ON AND USING A LONG MATCH OR BUTANE LOG LIGHTER. LIGHT RAISED REAR BURNER FIRST BY POSITIONING MATCH OR LIGHTER JUST OVER RAISED REAR BURNER WHILE TURNING ON GAS VALVE. AFTER RAISED REAR BURNER LIGHTS, YOU CAN USE CONTROL TOOL FOR LOWER ADJUSTABLE BURNER TO DESIRED FLAME HEIGHT. A MODERATE FIRE DURING THE FIRST 4 HOURS OF BURN TIME IS RECOMMENDED. DO NOT OVERFIRE AT ANYTIME.

FOR YOUR SAFETY, READ BEFORE LIGHTING

WARNING: IF YOU DO NOT FOLLOW THESE INSTRUCTIONS EXACTLY, A FIRE OR EXPLOSION MAY RESULT CAUSING PROPERTY DAMAGE, PERSONAL INJURY OR LOSS OF LIFE.

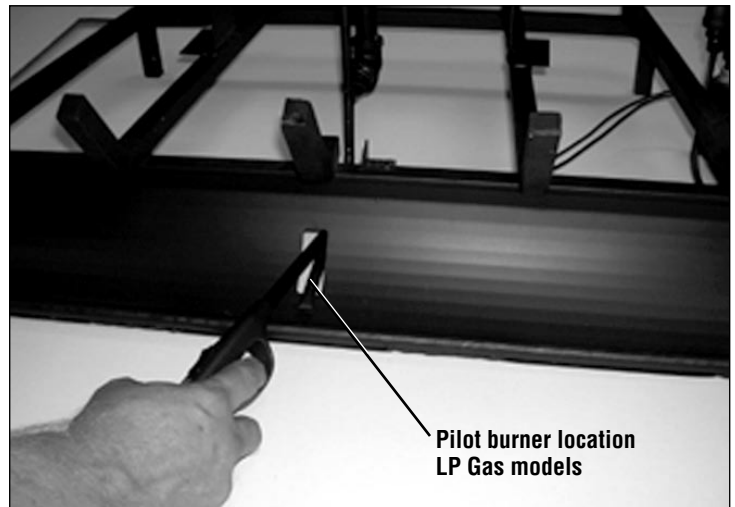
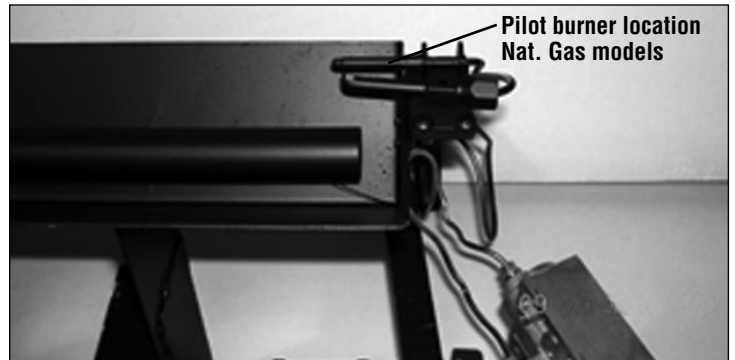
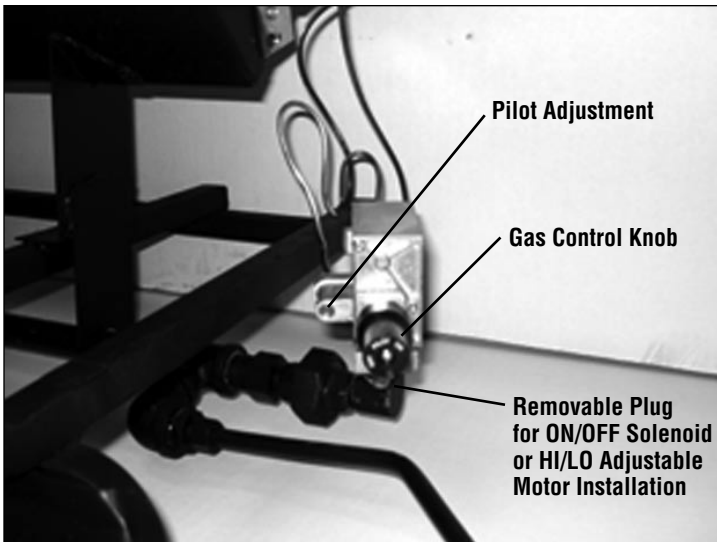

1. This product has a standing pilot, which must be lit by hand. When lighting the pilot, follow these instructions exactly.
2. This installation should be installed including provisions for combustion and ventilation air, must conform with local codes or, in the absence of local codes, to the National Fuel Gas Code, ANSI Z223 latest edition.
3. This product must be on a gas supply line that is less than 1/2 psi. and with an individual manual shut off.
4. **Never** operate this new system with the glass fireplace enclosures (doors) in the **closed position**.
5. Connecting 110-volt electrical power to this product will cause damage and will void warranty.

3 IN 1 GAS CONTROL VALVE LIGHTING INSTRUCTIONS





Pilot Gas and Lighting Procedure

DAMPER MUST BE FULLY OPENED

1. Turn the gas control knob counter-clockwise  to the PILOT position, push the gas control valve IN and HOLD in position. This will open the pilot valve and allow gas to flow to the pilot burner.
2. Light the pilot burner while holding the gas control knob in until a strong pilot flame is present (approximately 60 seconds).
3. Release the gas control knob. The gas control knob will hold in and engages the valve power unit.
4. Turn the gas control knob counter-clockwise  to the ON position. The main burner valve will open and the main burner will ignite.

Shut Off Procedure

1. To shut OFF the main burner but leaving the pilot ON, turn the gas control knob clockwise  to the PILOT position. This action will close the main gas flow.
2. To shut OFF the main burner and pilot, turn the gas control knob clockwise  to the OFF position. This action will close the main gas valve and disengages the safety pilot valve. However, the power unit must drop out before the lighting sequence can begin again. This may take as long as 3 minutes.
3. To relight the pilot, follow the steps in the Pilot Gas and Lighting Procedure section.

ALL GOLDEN BLOUNT GAS LOG PRODUCTS USING THE 3 IN 1 GAS CONTROL VALVE CAN BE EASILY CONVERTED TO AN OFF/OFF SOLENOID OR AN ADJUSTABLE MOTOR FLAME HEIGHT. ASK YOUR DEALER OR CALL 1-800-833-1139.

HIGH OUTPUT GAS CONTROL VALVE LIGHTING INSTRUCTIONS

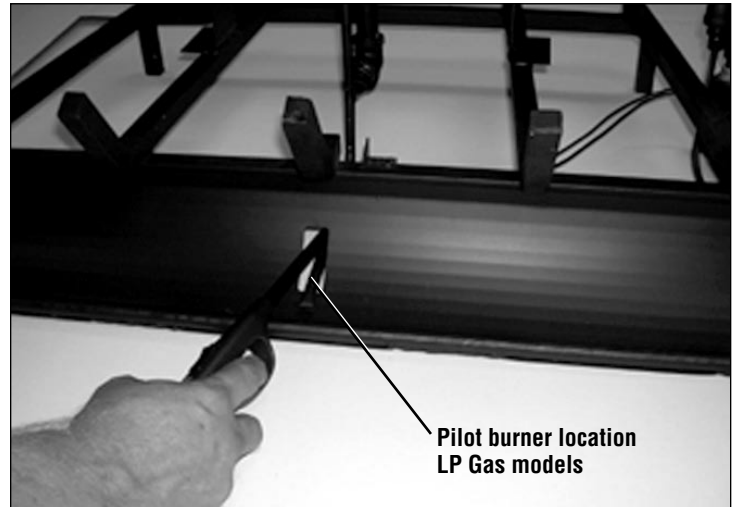
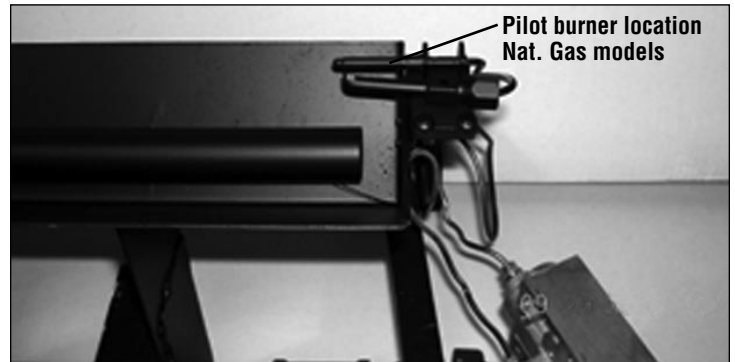
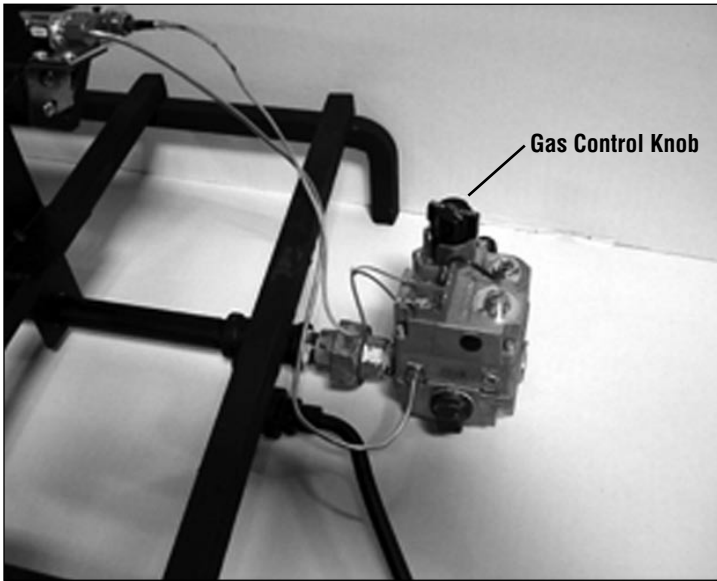

FOR YOUR SAFETY, READ BEFORE LIGHTING

WARNING: If you do not follow these instructions exactly, a fire or explosion may result causing property damage, personal injury or loss of life.

- A.** The Golden Blount Gas Log Set has a pilot which must be lighted by hand. When lighting the pilot, follow these instructions exactly.
- B. BEFORE LIGHTING,** smell all around the gas log set area for gas. Be sure to smell next to floor because some gas is heavier than air and will settle on the floor.

WHAT TO DO IF YOU SMELL GAS

- Do not try to light any appliance.
 - Do not touch any electrical switch, do not use any phone in your building.
 - Immediately call your gas supplier from a neighbor's phone. Follow the gas supplier's instructions.
 - If you cannot reach your gas supplier, call the fire department.
- C.** Use only your hand to push in or turn the gas control knob. Never use tools. If the knob will not push in or turn by hand, don't try to repair it. Call a qualified service technician. Force or attempted repair may result in fire or explosion.
- D.** Do not use the gas log set if any part has been under water. Immediately call a qualified service technician to inspect the gas log set and to replace any part of the control system and any gas control which has been under water.
- E.** FIREPLACE DAMPER MUST BE FULLY OPENED.

1. **"Stop!"** First read the safety information at the left.
2. Turn the control to the "OFF" position. To do this, you must turn the knob clockwise ↻ to the PILOT position and then press in and continue turning clockwise ↻ to the "OFF" position.
3. **WAIT FIVE (5) MINUTES TO CLEAR OUT ANY GAS.** If you then smell gas, STOP! Follow step "B" in the safety information at the left. If you don't smell gas, go to the next step.
4. To put the control in the pilot position, turn the control knob counter-clockwise ↺ to the "PILOT" position.
5. To light the pilot, depress the control knob and light the pilot using a long match or extended butane lighter. The control knob should be held IN for 1 minute.
6. Release the control knob. The pilot should remain lit after releasing.
7. Turn the control knob counter-clockwise ↺ to the "ON" position and turning on switch or remote attached to the "TH" and "TH-PG" terminals on valve.

To Turn Off Gas To Appliance

1. Turn off switch or remote.
2. Turn control knob clockwise ↻ to "PILOT".
3. Depress control knob slightly and turn clockwise ↻ to "OFF".

LIMITED WARRANTY

Golden Blount Gas Logs are warranted against defective materials and/or workmanship for as long as you own them. Burner pan assemblies are guaranteed for five years from date of purchase. Safety Pilot Assemblies are covered for one year.

This warranty does not cover parts subjected to misuse, abuse, improper handling or improper installation. The GB warranty specifically excludes any liability for indirect, incidental or consequential damage to property.

Defective logs or defective parts should be returned to your dealer or to the factory prepaid with a copy of your sales receipt. Defective parts will be repaired or replaced at the factory's option and returned to you prepaid.



GOLDEN BLOUNT – 4301 WESTGROVE DRIVE – ADDISON, TX 75001