

**INSTALLER/CONSUMER RETAIN THIS APPLIANCE  
MANUAL WITH THE INSTALLED APPLIANCE**



# INSTALLATION AND OPERATING INSTRUCTIONS



GOLDEN BLOUNT  
SUPER-FIRE

MODEL SF3624-TV TOP-VENT FIREPLACE

CSA APPROVED FOR NATURAL GAS OR PROPANE GAS

**IMPORTANT! Read all instructions carefully before starting installation. Failure to follow these instructions may result in property damage, personal injury or possible loss of life.**

**WARNING:** If the information in these instructions is not followed exactly, a fire or explosion may result causing property damage, personal injury or death.

– Do not store or use gasoline or other flammable vapors and liquids in the vicinity of this or any other appliance.

**– WHAT TO DO IF YOU SMELL GAS:**

- Do not try to light any appliance.
  - Do not touch any electrical switch; do not use any phone in your building;
  - Immediately call your gas supplier from a neighbor's phone. Follow the gas supplier's instructions.
  - If you cannot reach your gas supplier, call the fire department.
- Installation and service must be performed by a qualified installer, service agency or the gas supplier.

- The Flue Damper must be in the full open position when burning the gas logs.
- This fireplace is to be burned only with the gas log set supplied with the fireplace. Burning other items could cause a fire hazard or injury.
- For best results, Natural Gas pressure should be 7" to 12" W.C. and 11" W.C. for Propane Gas.
- To simulate real wood burning, the gas burner is designed to burn a yellow flame. It is normal for the logs to soot-up. The soot can be easily removed with a vacuum cleaner or soft brush.
- Check the label on the firebox to assure the proper gas type. Never use anything but the correct gas type for your fireplace.

This appliance complies with National Safety and is tested and listed to ANSI Z21.50b - 2009 as Vented Gas fireplaces. Installation must conform to local codes. In the absence of local codes, installation must conform with the current National Fuel Gas Code, ANSI Z223.1.

Massachusetts State Code requires damper to be welded open or removed.

MANUFACTURED BY:

4301 WESTGROVE DRIVE  
ADDISON TX. 75001

## TABLE OF CONTENTS

### **SECTION**

Layout Options .....	2
Identification of Parts .....	3
Building Codes and Safety Standards.....	4
Piping and Gas Pressure Requirements .....	5
Installation Instructions .....	6
Brick Panels, Exhaust and Downdraft Diverter Instructions (Refractory Models) .....	9
Log Placement.....	11
Operating Guidelines (Millivolt Models) .....	12
Lighting Instructions (Millivolt Models).....	14
Trouble Shooting (Millivolt Models) .....	15
Operating Guidelines (Spark to Pilot Models) .....	19
Lighting Instructions (Spark to Pilot Models) .....	20
Trouble Shooting (Spark to Pilot Models).....	22
Replacement Parts .....	24

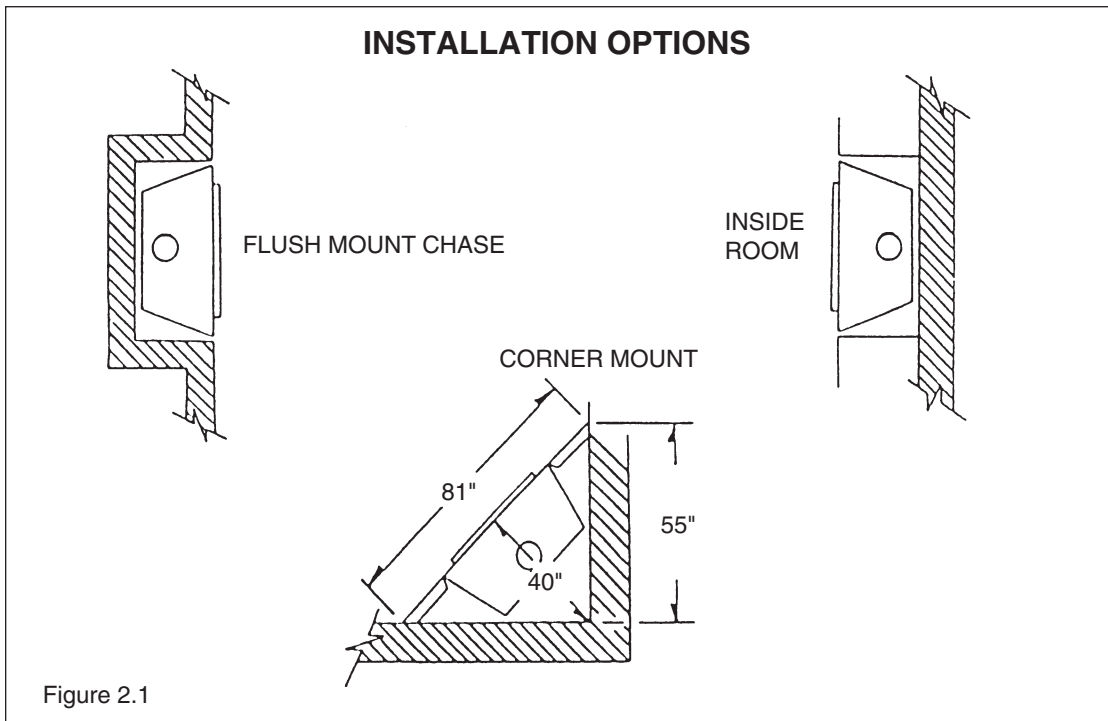

# SF3624-TV TOP-VENT FIREPLACE

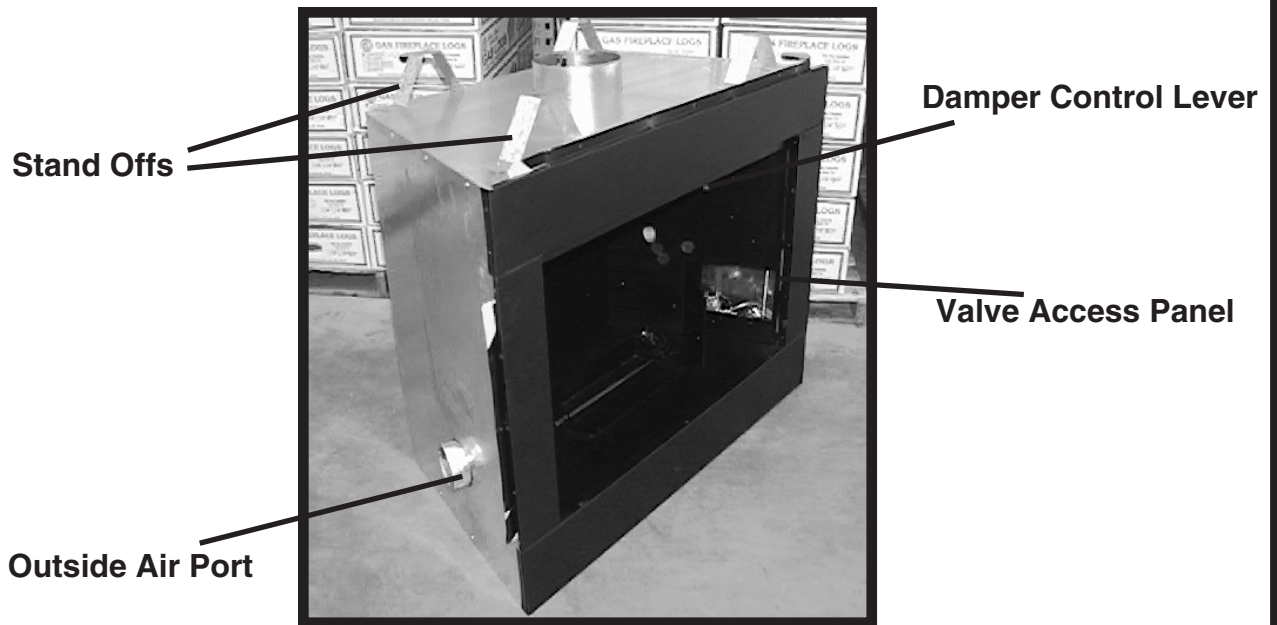

## INTERIOR VIEW

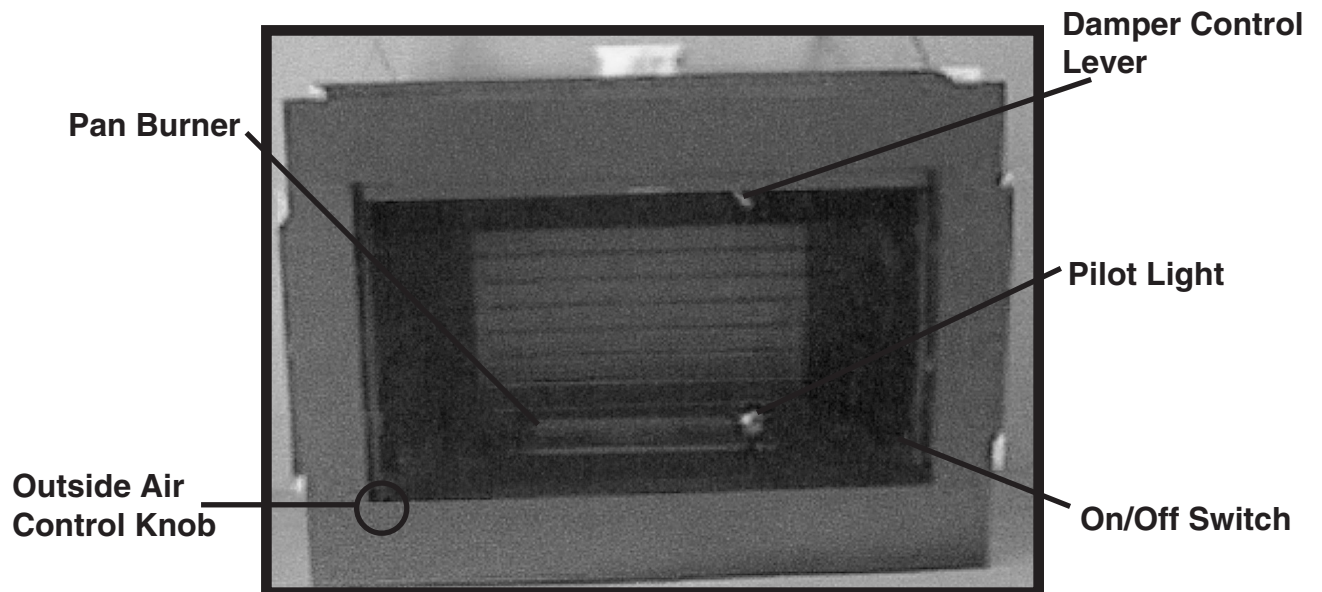

## BUILDING CODES AND SAFETY STANDARDS

The design of this FIREPLACE ACCESSORY has been tested and is listed with CSA INTERNATIONAL in accordance with THE AMERICAN NATIONAL STANDARDS INSTITUTE - ANSI Z21.50, CSA Test Report No. 188842-1049553.

This manual serves only as a basic guideline for installation and use of this firebox and gas piping. The complete installation must be in accordance with local codes and ordinances, or, in the absence of local codes, with the American National Standards Institute National Fuel Gas Code Z223.1 latest edition.

### GENERAL INFORMATION

MODEL SF3624-TV IS A TOP-VENTED DECORATIVE GAS APPLIANCE. IT IS DESIGNED TO BURN BY DRAWING COMBUSTION AIR FROM THE OUTSIDE AIR KIT THAT ATTACHES TO THE LEFT SIDE OF THE FIREPLACE.

THE EXHAUST FLUE GASES ARE TO BE VENTED THROUGH THE TOP-VENT USING 8" B-TYPE GAS VENT PIPE. ALL-FUEL CLASS A CHIMNEY PIPE MAY ALSO BE USED.

THE CONTROL SYSTEM IS A MILLIVOLT TYPE THAT INCLUDES A ON-OFF SHUT-OFF VALVE, A GAS CONTROL VALVE, A STANDING PILOT LIGHT ASSEMBLY, PIEZO IGNITOR AND ON-OFF ROCKER SWITCH.

**WARNING:** THIS UNIT IS NOT FOR USE WITH SOLID FUEL.

**NOTE:** INSTALLATION AND REPAIR SHOULD BE DONE BY A QUALIFIED SERVICE PERSON. THE APPLIANCE SHOULD BE INSPECTED BEFORE USE AND AT LEAST ANNUALLY BY A PROFESSIONAL SERVICE PERSON. MORE FREQUENT CLEANING MAY BE REQUIRED DUE TO EXCESSIVE LINT FROM CARPETING, BEDDING MATERIAL, ETC. IT IS IMPERATIVE THAT THE UNITS CONTROL COMPARTMENT, BURNERS, AND CIRCULATING AIR PASSAGE-WAYS BE KEPT CLEAN TO PROVIDE ADEQUATE COMBUSTION AND VENTILATION AIR.

### CLEARANCES REQUIRED

MINIMUM CLEARANCES FOR THE FIREBOX ARE:

1/2" ON THE SIDES AND BACK AND 0 AT THE BOTTOM. TOP CLEARANCE IS 3" WHICH IS THE HEIGHT OF TOP STANDOFFS, SEE FIGURE 7.1 FOR FRAMING DIMENSIONS:

**NOTE:** PROVIDE ADEQUATE CLEARANCES AROUND AIR OPENINGS INTO THE COMBUSTION CHAMBER.

**NOTE:** ADEQUATE ACCESSIBILITY CLEARANCES FOR SERVICING AND PROPER OPERATION MUST BE PROVIDED IN ACCORDANCE WITH ANSI Z21.50b - 2009.

## GAS PIPING AND GAS PRESSURE REQUIREMENTS

All gas piping must be installed to comply with local codes, or, in the absence of local codes, with the latest edition of the National Fuel Gas Code ANSI Z223.1.

Unions in gas lines shall be of ground joint type. Compounds used on threaded joints of gas piping must be resistant to the action of liquefied petroleum gas. Gas piping must be of sufficient size to provide a minimum natural gas pressure at the appliance of 7" water column or 11" for L.P. gases for the purpose of input adjustment. The maximum inlet gas pressure to the unit must not exceed 10" for natural gas, and 13" for LP gases. If this unit is to be supplied with LP gas (bottled propane) the tank or bottle supplying the gas must have a regulator that reduces the gas pressure to between 11 and 13 inches water column. The control will not operate with gas line pressure directly from the tank and may leak gas due to this excessive pressure.

**DANGER:** OPERATION OF THIS UNIT ON LP GAS WITHOUT AN APPROVED REGULATOR AT THE SUPPLY CONTAINER WILL LEAD TO GAS LEAKS AT THE CONTROL WITH POSSIBLE FIRE OR EXPLOSION.

Include a manual shut-off valve and union in the line so the control or heater may be disconnected for servicing. Include a drip leg and a plugged 1/8" N.P.T. tapping into the line also. The tapping must be accessible for the test gauge connection immediately upstream of the gas supply connection to the unit. Use a soap and water solution or liquid gas leak detector to coat each joint in the piping system and look for bubbles which indicate gas leaks. Repair all gas leaks.

**CAUTION:** THE UNIT AND ITS INDIVIDUAL SHUT-OFF VALVE MUST BE DISCONNECTED FROM THE GAS SUPPLY PIPING SYSTEM DURING PRESSURE TESTING OF THAT SYSTEM AT TEST PRESSURES IN EXCESS OF 1/2 PSIG. THE UNIT MUST BE ISOLATED FROM THE GAS SUPPLY PIPING SYSTEM BY CLOSING ITS INDIVIDUAL MANUAL SHUT-OFF VALVE DURING ANY PRESSURE TESTING OF THE GAS SUPPLY PIPING SYSTEM AT TEST PRESSURES EQUAL TO OR LESS THAN 1/2 PSIG. PRESSURES IN EXCESS OF 1/2 PSIG WILL CAUSE DAMAGE TO THE CONTROL VALVE AND MAY CAUSE DAMAGE TO THE SHUT-OFF VALVE.

**DANGER:** DO NOT USE CANDLES, MATCHES OR OTHER IGNITION SOURCES WHEN CHECKING FOR LEAKS. FUEL GASES ARE VERY FLAMMABLE AND IN CERTAIN CONCENTRATIONS, EXPLOSIVE . CHECKING FOR LEAKS WITH AN OPEN FLAME MAY LEAD TO FIRE OR EXPLOSION.

## INSTALLATION INSTRUCTIONS

In planning the installation for the fireplace it is necessary to determine where the unit is to be installed, the routing of the B-type vent system, and whether optional accessories are to be used gas supply piping should also be planned.

Model SF3624-TV (with the use of the Outside Air Kit) can be installed in a bedroom (in the United States) which has a total volume of unconfined space appropriate to the particular installation. Refer to the National Fuel Gas Code ANSI Z223.1/NFPA 54 - (current edition), the Uniform Mechanical Code - (current edition), and Local Building Officials for the options allowed in obtaining an effective bedroom volume of unconfined space.

The fireplace can be mounted on any of the following surfaces:

1. A flat combustible surface.
2. A raised wooden platform.
3. Four (4) corner supports.

(Example: four (4) concrete masonry blocks.) These supports must be positioned so they contact all four corner edges on the bottom of the unit.

If the fireplace is installed directly on carpeting, tile, or other combustible material other than wood flooring, the appliance shall be installed on a metal or wood panel extending the full width and depth of the unit.

Fireplace framing can be built before or after the fireplace is set in place. Framing should be positioned to accommodate wall covering and fireplace facing material. The fireplace framing should be constructed of 2 x 4 lumber or heavier. The framing headers may rest on the fireplace standoffs. Refer to Figure 7.1 for fireplace and framing reference dimensions.

### **CAUTION: VERIFY FIREPLACE DIMENSIONS, FRAMING METHODS AND WALL COVERING DETAILS BEFORE FRAMING CONSTRUCTION BEGINS.**

Determine the exact position of the fireplace so that the vent run can be planned. Figure 2.1 shows possible locations for the fireplace; inside of a room, flush mount in a chase, or installed in a corner. Using a level, make sure the fireplace is properly positioned and squared.

### **WARNING: DUE TO HIGH TEMPERATURES, THE APPLIANCE SHOULD BE LOCATED OUT OF TRAFFIC AND AWAY FROM FURNITURE AND DRAPERIES. CLOTHING OR OTHER FLAMMABLE MATERIAL SHOULD NOT BE PLACED ON OR NEAR THE APPLIANCE.**

Please note: B-Vent appliances are not designed to operate in negatively pressured environments (pressure within the home is less than pressures outside). Significant negatively pressured environments caused by weather, homes built airtight or other devices may impact the operation of this appliance. Negative pressures may result in poor flame appearance, sooting, damage to property and/or severe personal injury. Do not operate this appliance in negatively pressured environments.

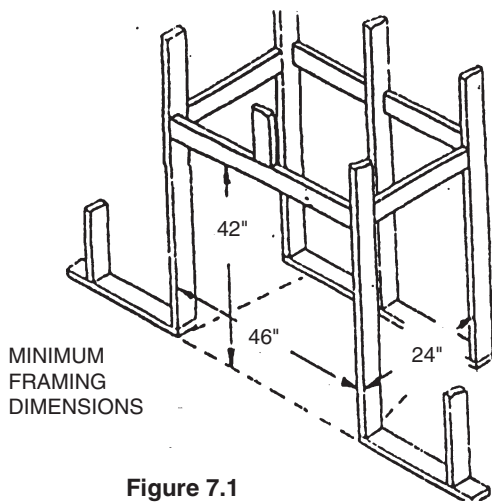
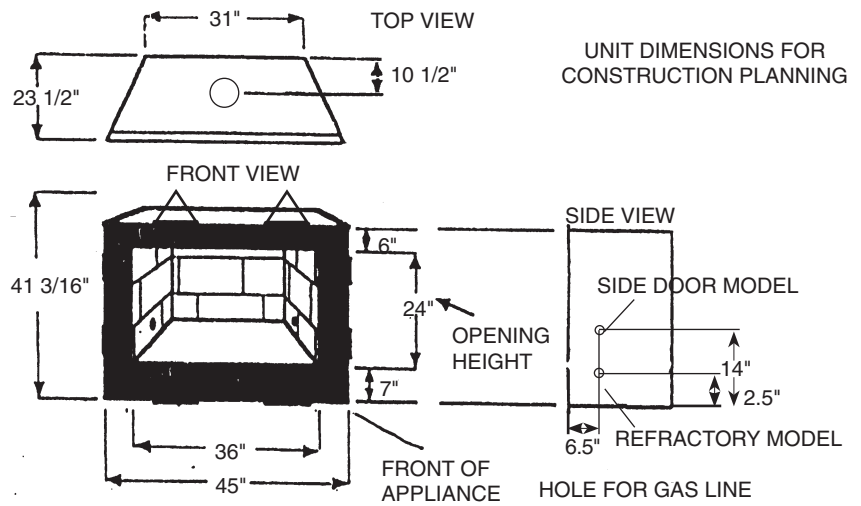

Figure 7.1



### Installing Chimney/Vent System

Model SF3624TV is approved to be used with 8" B-Type Gas Vent or 8" class-A All Fuel Chimney. Under most conditions the fireplace system will draw properly if the chimney height is determined in accordance with the following guidelines:

**Note: (90-degree elbows are not approved! Maximum offset angle must not exceed 45 degrees.) Many manufacturers of B-Type gas vent offer "High Performance," or "High Wind" caps. These caps limit the outlet area for flue gasses to expel and should not be used with this fireplace. In the event of draft related problems due to extreme wind conditions a special wind ring is available.**

1. If your chimney penetrates the roof within 10' of its peak, it must be extended at least 24" above your roof's peak and be at least 36" above the highest point of the roof opening, (see below).
2. If the chimney penetrates the roof farther than 10' from its peak, measure from the centerline of the chimney to a point 10' away, between the chimney and the peak of the roof. The top of the chimney must be at least 36" above the highest point of the roof opening, (see below).
3. The 10' Rule of Thumb is a guide for calculating chimney height that works under most conditions. However, many factors can cause the need for additional chimney height beyond what 10' Rule of Thumb would indicate. Topographical factors can cause high-pressure zones, which prevent a chimney from drawing. This can occur if the house is located in a low-lying area, in a valley or near the base of a cliff or hillside. The same situation can occur if the chimney is near other steep rooflines or tall buildings. Areas with high winds also frequently require higher than normal chimneys.

Certain styles of architecture tend to interfere with a fireplace's draw. If the room in which the fireplace is located has a very high ceiling, smoke may enter the room unless the chimney is terminated at a level higher than that of the ceiling, even if the 10' Rule of Thumb indicates a shorter chimney height.

**Note:** Installations which will not allow the 10' rule to be followed must be submitted to Golden Blount Inc. for approval. 1-800-833-1139.

**Warning!** This gas appliance must not be connected to a chimney flue serving a separate solid-fuel burning appliance.

Note: A draft hood is installed and is in the same atmospheric pressure zone as the combustion air inlet to the appliance and is located so that the relief opening is accessible for checking vent operation.

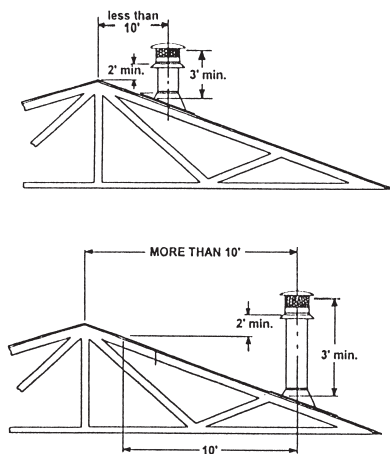

If your plans do not allow for the venting system as outlined previously in the "Installing chimney/vent system" section, you may contact ENERVEX, Inc. (formerly EXHAUSTO) at 800-255-2923. They will design an approved venting system to suit your venting needs. These power vented systems follow the standards and codes as outlined under the NFPA 54/ANSI Z223.1 Nation Fuel Gas Code. Please check with the local authority having jurisdiction in your area.

The engineers at ENERVEX are familiar with Golden Blount fireplaces and their systems will allow you to minimize the amount of vent pipe exposed outside of your home. Fireplaces may also be horizontally vented with these systems.

## Installing Outside Air Kit

Model SF3624-TV is supplied with the component parts for outside combustion with the exception of the 4" flex duct. It is recommended that the outside air system be used whenever possible. Connect 4" Class-1 Flex duct or Metal Vent to duct collar on side of firebox, run duct to fresh air source and terminate using duct termination cap. The Outside air can be opened by pushing control knob toward back of fireplace and closed by pulling towards front (Refer to figure 7.2).

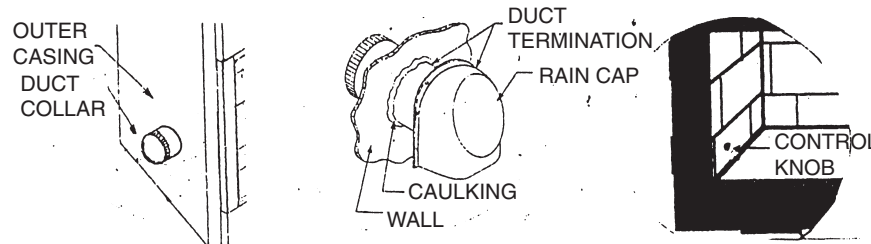

Figure 7.2

## Connecting the Gas Line

Consult local building codes before gas line installation. This gas fireplace is designed to accept a 3/8" male flare fitting attached to a 1/2" supply line. Have the gas line installed by a qualified service person in accordance with all building codes. Install gas line to fireplace on the right side attaching gas line to the gas flex line inside the control box accessed by opening the control box door.

## Finishing the Wall

Finish the wall with the material of your choice. Do not install a combustible mantle or other combustible projection above the fireplace opening unless it is a minimum of 12 inches above top of fireplace opening.

\*Non-combustible material used between top of opening and mantle must not exceed 3" in depth. (Figure 8.1)

Figure 8.1

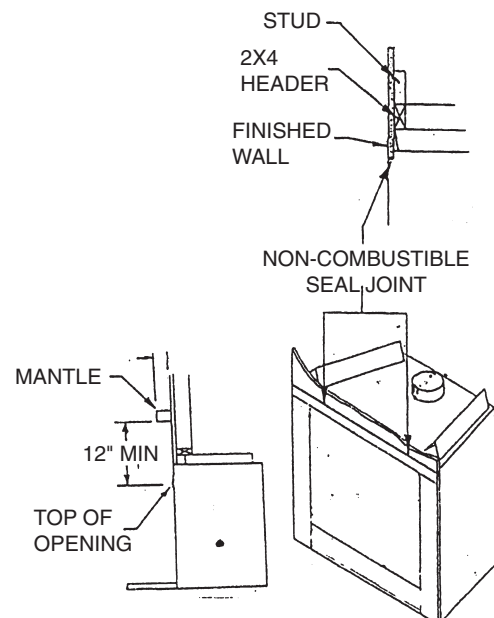

**CAUTION:** All joints between the finished wall and the fireplace surround (Top and Sides) can only be sealed with non-combustible material. Only non-combustible material can be applied as facing to the fireplace surround. (Figure 8.1)

## Hearth Extension

A Hearth Extension may be installed. But it is not required for decorative gas appliances.

## Gas Log Installation

1. Fill burner pan with vermiculite supplied with log set. Note! On L.P. models be careful not to pour vermiculite over brass air mixer attached to burner pan. Air mixer holes must not be obstructed!
2. Spread the ember material over the vermiculite.
3. At this time, we suggest you test fire the burner. Refer to start up instructions on page 12. **Important! The fireplace damper must be in full open position.**
4. Place the grate over the burner and install the logs as illustrated on page 9.
5. The last step is to cover floor of fireplace with volcanic rock around the sides and in front of burner pan to enhance overall appearance. Note: On L.P. models be careful not to pour black cinders over brass air mixer attached to burner pan. Air mixer holes must not be obstructed!

## INSTALLATION INSTRUCTIONS REFRACTORY BRICK PANELS, DOWNDRAFT DIVERTER, AND EXHAUST DIVERTER SF3624 SUPERFIRE FIREPLACE

This model Golden Blount top vent fireplace is supplied with high quality realistic Refractory Brick Panels. These panels are massive and must be field-installed to prevent damage to panels or fireplace during shipping. The field installation of panels also requires the Downdraft Diverter, and Exhaust Diverter to be installed in the field as well.

### REFRACTORY PANEL INSTALLATION

The Refractory Brick Panels should be carefully removed from shipping sleeve and positioned upright against a stable object.

1. Look into fireplace opening and locate back panel retaining clip positioned against rear wall of fireplace. (Figure 1). Remove (2) screws attaching clip to rear wall and set clip and screws aside. Position rear panel against rear wall and reattach clip with (2) screws.
2. Locate left panel retaining clip and remove (2) screws and set clip and screws aside. Position left panel against left wall and reattach clip with (2) screws.
3. Repeat Step 2 for right panel installation.

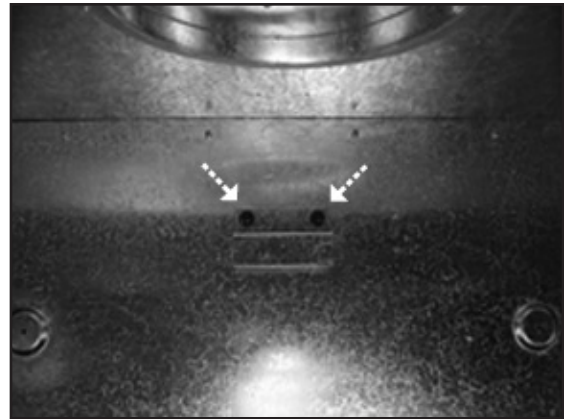

Figure 1

### DOWNDRAFT DIVERTER INSTALLATION

The Downdraft Diverter prevents heavy downdrafts from altering pilot and main burner operation.

1. Look inside fireplace opening and locate (2) screws in roof of interior firebox. Remove screws and position Downdraft Diverter as shown in Figure 2. Attach Diverter with (2) screws removed earlier.

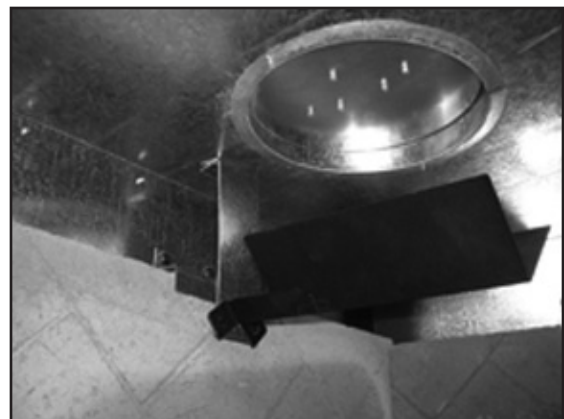

Figure 2

## EXHAUST DIVERTER INSTALLATION

The Exhaust Diverter prevents exhaust gasses from entering the room.

1. Locate screws attached to front side top of interior firebox and remove. (Figure 3).
2. Position Exhaust Diverter into fireplace and attach Diverter using screws removed earlier. Diverter should be positioned as shown. (Figure 4).

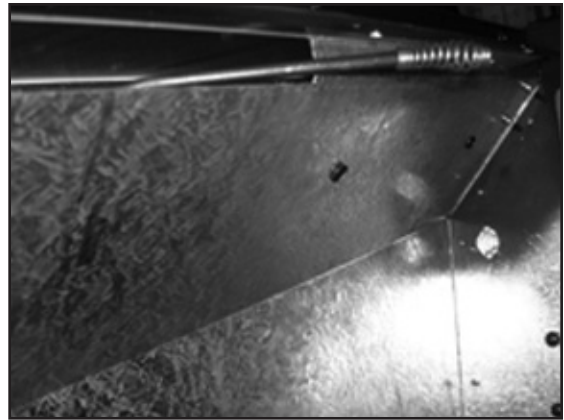

Figure 3

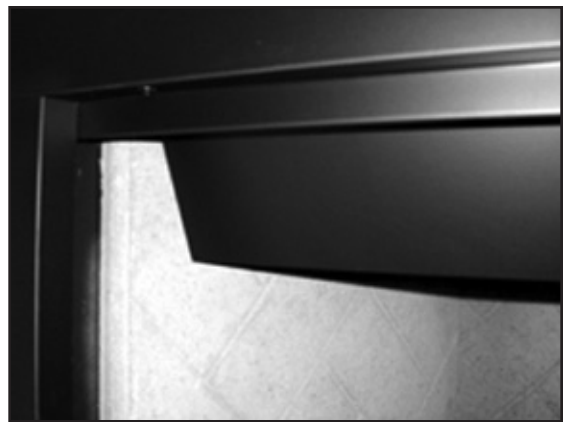
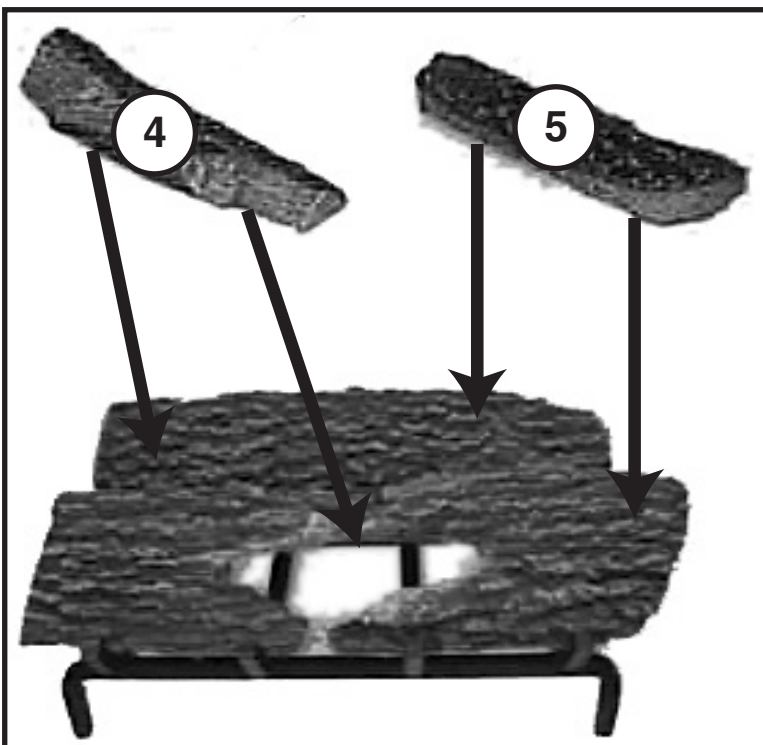
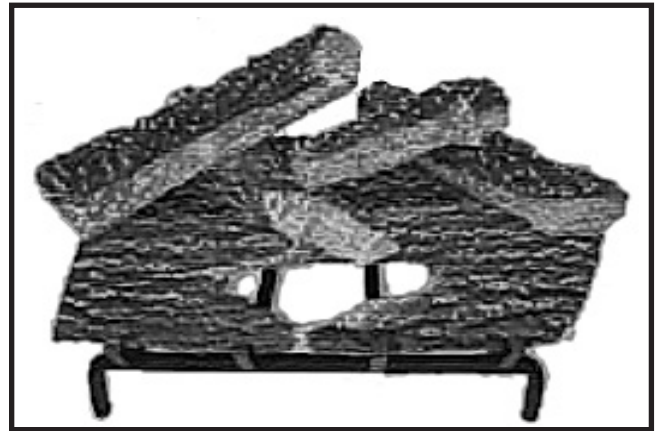
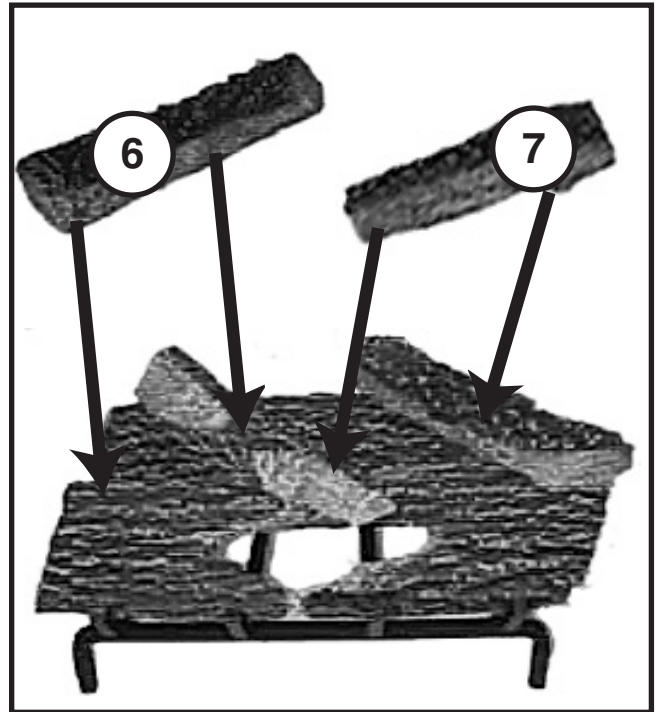
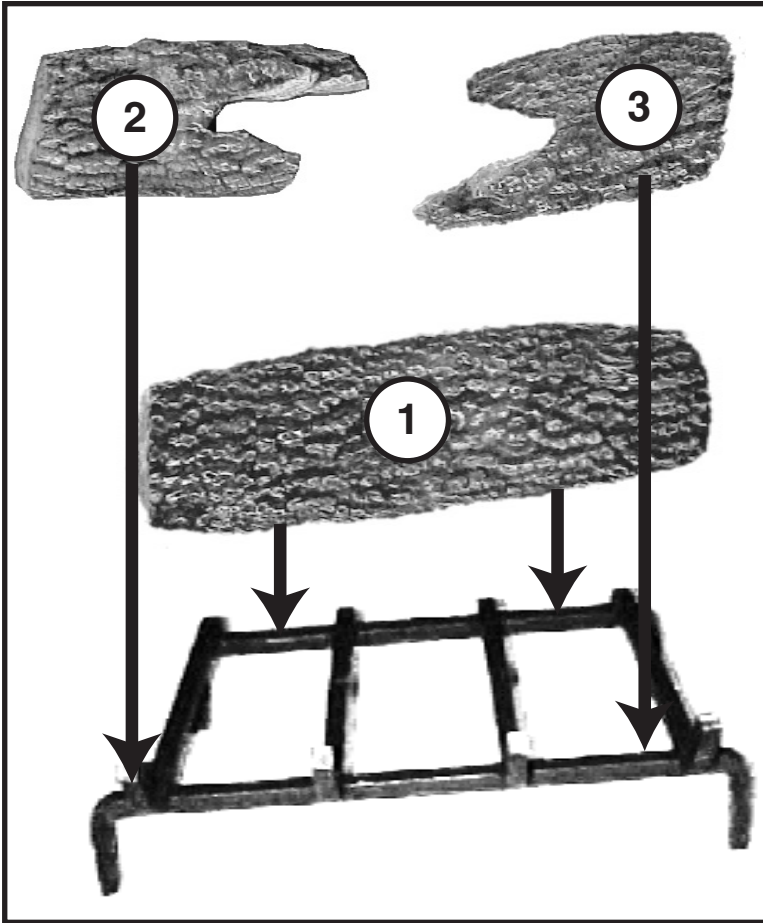

Figure 4



# LOG PLACEMENT FOR MODEL# SF3624TBF LOG SET

NOTE: FOR SF3624 STACK LOG PLACEMENT, SEE SHEET IN LOG CTN.



## Placement Instructions

- Place the back bottom log (log #1) as shown in the illustration above. It should be positioned on the back of the grate.
- Place the front bottom log pieces (logs #2 and #3) as shown. They should be positioned on the front of the grate.
- The front bottom log pieces (logs #2 and #3) should be touching each other in order to form what will look like a rotten or burned out chamber in the front log section (see bottom left picture).
- Log #4 and #5 should be placed on top of bottom logs as shown in bottom left picture.
- Log #6 and #7 should be placed on top as shown in top right picture.
- Bottom right picture shows final log arrangement.

## OPTIONAL GLASS DOOR INSTALLATION

1. INSTALL GB DOOR TRACKS AND HINGE SPRINGS AS ILLUSTRATED IN FIGURE 1 USING 6 SCREWS IN KIT.
2. SCREW HANDLES ON TO DOORS.
3. INSTALL DOORS AS SHOWN IN FIGURE 2.

### **NOTE!**

- HINGE SPRINGS CAN BE MOVED TO ADJUST DOOR ALIGNMENT.
- DOOR LOCKING TABS CAN BE SET BY BENDING UP OR DOWN. SEE FIGURE 3.
- USE MILD SOAP AND WATER TO CLEAN METAL SURFACES.
- DO NOT USE BRASS OR ABRASIVE CLEANERS.
- ALLOW GLASS TO COOL BEFORE CLEANING.

### **CAUTION!**

- BURN WITH DOORS ONLY IN FULL OPEN POSITION.**
- BROKEN OR DAMAGED COMPONENTS NEED TO BE REMOVED CAREFULLY. BROKEN GLASS OR HARDWARE CAN BE REPLACED BY ORIGINAL FACTORY PARTS ONLY. BROKEN GLASS MUST BE REPLACED BY COMPLETE FACTORY ASSEMBLED BIFOLD ONLY.**
- DO NOT SUBSTITUTE ANY MATERIALS NOT MANUFACTURED SPECIFICALLY FOR THIS APPLIANCE.**
- DO NOT STRIKE OR SLAM GLASS DOORS WHEN CLOSING.**
- DO NOT OPERATE THIS APPLIANCE IF GLASS IS BROKEN.**
- ALLOW GLASS TO COOL BEFORE CLEANING GLASS PANES. GLASS PANES CAN BE CLEANED WITH A NON-ABRASIVE GLASS CLEANER.**

### **OPERATING GUIDELINES (MILLIVOLT MODEL)**

Upon completing the gas line connection, a small amount of air will be in the lines. When first lighting the pilot light, it will take a few minutes for the lines to purge themselves of this air. Once the purging is complete, the pilot and burner will light and operate as indicated in the instruction manual. Subsequent lighting of the appliance will not require such purging.

**CAUTION: DURING THE INITIAL PURGING AND SUBSEQUENT LIGHTING, NEVER ALLOW THE GAS VALVE CONTROL KNOB TO REMAIN DEPRESSED IN THE "PILOT" POSITION WITHOUT PUSHING THE RED IGNITOR BUTTON AT LEAST ONCE EVERY SECOND.**

**WARNING: CHILDREN AND ADULTS SHOULD BE ALERTED TO THE HAZARDS OF HIGH SURFACE TEMPERATURE AND SHOULD STAY AWAY TO AVOID BURNS OR CLOTHING IGNITION. YOUNG CHILDREN SHOULD BE CAREFULLY SUPERVISED WHEN THEY ARE IN THE SAME ROOM AS THE APPLIANCE.**

**IMPORTANT: TURN OFF GAS BEFORE SERVICING APPLIANCE. IT IS RECOMMENDED THAT A COMPETENT SERVICE TECHNICIAN- PERFORM THESE CHECKUPS AT THE BEGINNING OF EACH HEATING SEASON.**

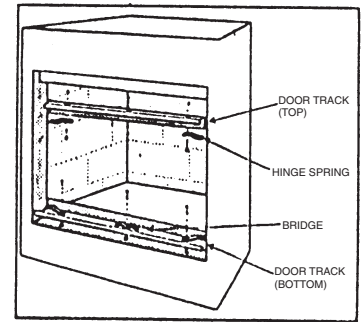

FIGURE #1

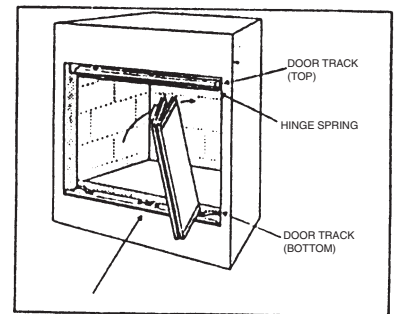

FIGURE #2

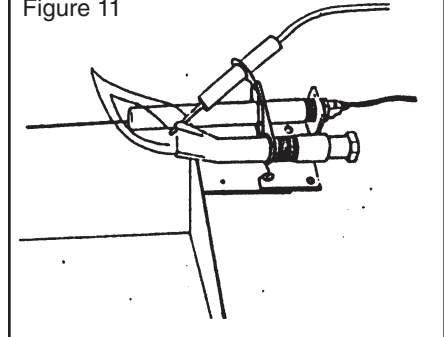

FIGURE #3

## OPERATING GUIDELINES (CONT'D)

When lit for the first time, the appliance will emit a slight odor for an hour or two. This is due to paint and lubricants used in the manufacturing process. The main burner flame characteristics are steady, not lifting or floating. Typically, the top 3/4 inch of the pilot generator should be engulfed in the pilot flame. A periodic check of these characteristics is necessary.

Figure 11



**CAUTION: THE LOGS CAN GET VERY HOT!  
HANDLE ONLY WHEN COOL**

## MAINTENANCE INSTRUCTIONS

Visually inspect pilot periodically. Brush or blow away any dust or linen accumulations. If pilot orifice is plugged, disassembly may be required to remove any foreign material from orifice or tubing.

Venting system should be periodically examined by a qualified service technician or agency to ensure proper air flow.

## WIRING DIAGRAM (MILLIVOLT MODEL)

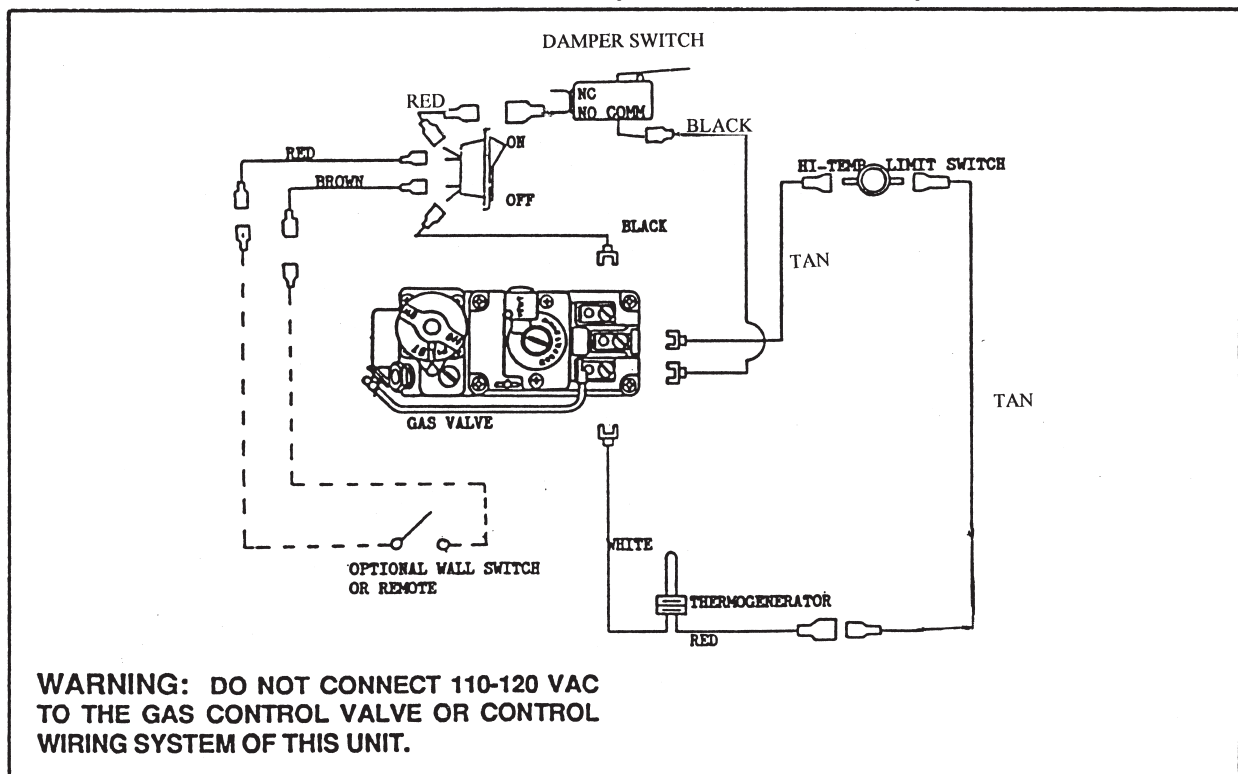

## FOR YOUR SAFETY READ BEFORE LIGHTING

**WARNING: IF YOU DO NOT FOLLOW THESE INSTRUCTIONS EXACTLY, A FIRE OR EXPLOSION MAY RESULT CAUSING PROPERTY DAMAGE, PERSONAL INJURY OR LOSS OF LIFE.**

A. This appliance has a pilot. When lighting the pilot, follow these instructions exactly.

B. BEFORE LIGHTING smell all around the appliance area for gas. Be sure to smell next to the floor because some gas is heavier than air and will settle on the floor.

### WHAT TO DO IF YOU SMELL GAS:

- Do not try to light any appliance
- Do not touch any electric switch: Do not use any phone in your building.
- Immediately call your gas supplier from a neighbor's phone. Follow the gas supplier's instructions
- If you cannot reach your gas supplier call the fire department.

C. Use only your hand to push in or turn the gas control knob. Never use tools. If the knob will not push in or turn by hand don't try to repair it, call a qualified service technician. Forced or attempted repair may result in a fire or explosion.

D. Do not use this appliance if any part has been under water. Immediately call a qualified service technician to inspect the appliance and to replace any part of the gas control system which has been under water.

## LIGHTING INSTRUCTIONS

1. "STOP" Read the safety information above first.
2. To access controls, open valve access panel.
3. Turn the control to the "OFF" position. To do this, you must turn the knob clockwise to the pilot position and then press in and continue turning clockwise to the "OFF" position.

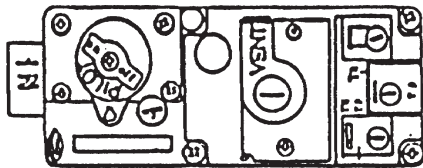

GAS VALVE

4. WAIT FIVE (5) MINUTES TO CLEAR OUT ANY GAS. If you then smell gas, STOP! Follow "B" in the safety information above. If you don't smell gas, go to next step.
5. The pilot should not require accessing for lighting purposes. The pilot is located inside the combustion chamber.
6. To put the control in the pilot position turn the control knob counter-clockwise to the pilot position

THERMOPILE



PILOT BURNER

7. To light the pilot depress the control knob and then depress the red piezo button until it makes a clicking sound. It may be necessary to repeat this step. If the pilot does not light after Ten seconds, go back to step 3. The control knob should be held Down for a MINUTE after pilot ignition. If the pilot lights, but will not stay lit after two tries, turn the gas control knob to the "OFF" position and call your Service technician or gas supplier. If the control knob does not pop out when released, STOP - shut off the gas supply to the fireplace control valve and immediately call your service technician or gas supplier
8. After the pilot has been lit, the Burner can be turned on by turning the knob counter-clockwise to the "ON" position. Then turn the ON/OFF switch to the "ON" position.  
**Note: Damper control lever must be in the "open" position to ignite.**

## TO TURN OFF GAS TO APPLIANCE

1. Open valve access door panel
2. Turn knob clockwise  to pilot position then depress and continue turning to "OFF"
3. Close access door panel

### LPG (PROPANE) WARNING

THE FOLLOWING WARNING APPLIES TO INSTALLATIONS USING L.P. (PROPANE GAS):

**WARNING:** To avoid possible injury, fire and explosion, please read and follow these precautions and all instructions of this appliance before lighting the pilot. This appliance uses L.P. (Propane) gas which is heavier than air and will remain at the floor level if there is a leak. Before lighting, smell at floor level and/or use other means (such as using a soap solution on all piping and connections, using a gas detector, etc.) to check for gas leaks. **NOTE:** L.P. (Propane) gas can become odorless and **CANNOT** always be detected by smell. If you smell gas, detect a gas leak or suspect that a gas leak exists, follow these rules:

1. Get all people out of building.
2. **DO NOT** light matches. **DO NOT** turn electric lights or switches on or off in area. **DO NOT** use an electric fan to remove gas from area. **DO NOT** use a telephone inside of building.
3. Shut off gas at L.P. tank outside of building.
4. Telephone gas company and fire department. Ask instructions. Before hanging up, give your name, address and phone number. **DO NOT** go back into building.

If your L.P. tank runs out of fuel, turn off gas at the appliance. After L.P. tank is refilled, appliance must be re-lit according to manufacturer's instructions. If the gas control has been exposed to **WATER** in any way, **DO NOT** try to use it. It must be replaced. **DO NOT** attempt repair on gas control or appliance.

Tampering is **DANGEROUS** and voids all warranties. Any component that is found to be faulty, must be replaced with an approved component.

**IMPORTANT: Always keep the appliance area clear and free from combustible materials, gasoline and other flammable vapors and liquids.**

**Never obstruct the flow of combustion and ventilation air. Keep the front of the appliance clear of all obstacles and materials.**

**To obtain proper operation, it is imperative that the pilot and main burner flame characteristics are steady, not lifting or floating. Typically the top 3/4 inch at the pilot generator should be engulfed in the pilot flame. (Figure 11)**

#### **IMPORTANT - PLEASE NOTE L.P. GAS MODELS**

MODERATE SOOT ACCUMULATION IS CONSIDERED NORMAL FOR L.P. GAS LOGS. TO KEEP THIS SOOT ACCUMULATION TO A MINIMUM, REDUCE THE FLAME IMPINGEMENT BY SPACING FRONT AND BACK LOGS AS FAR APART AS POSSIBLE.

## TROUBLE SHOOTING (MILLIVOLT MODEL)

With proper installation and maintenance, your new Gas Fireplace should provide years of trouble-free service. If you do experience a problem, refer to the trouble shooting guide shown below. This guide will assist a qualified service person in the diagnosis of problems and the corrective action to be taken.

<b>SYMPTOM</b>	<b>POSSIBLE CAUSE</b>	<b>CORRECTIVE ACTION</b>
1. Spark ignitor will not light pilot after triggering	A. Defective ignitor (no spark at electrode).	1. Check for spark at electrode and pilot; if no spark exist and electrode wire is properly connected, replace ignitor.
	B. Defective or misaligned electrode at pilot (spark at electrode)	1. Using a match, light pilot. If pilot lights, turn off pilot and trigger the red button again. If pilot lights, an improper gas/air mixture caused the bad lighting and a longer purge period is recommended. If pilot will not light - check gap at electrode and pilot should be 1/8 inch to have a strong spark. If OK, replace pilot
	C. No gas or low gas Pressure	<p>1. Check remote shut off valves from fireplace. usually there is a valve near the fireplace and sometimes there is a valve near the main. there can be more than one valve between the fireplace and main.</p> <p>2. Low pressure can be caused by a variety of situations such as a bent line, too narrow diameter of pipe or even low line pressure. Check for kinked lines. If none, consult with Plumber or gas supplier. If L.P. Gas is used you may be out of fuel.</p>

## TROUBLE SHOOTING (CONT'D)

<u>SYMPTOM</u>	<u>POSSIBLE CAUSE</u>	<u>CORRECTIVE ACTION</u>
2. Pilot will not stay lit after carefully following lighting instructions.	A. Defective pilot generator	<ol style="list-style-type: none"><li>1. Check pilot, flame must impinge on pilot generator. Clean and or adjust pilot for maximum flame impingement on generator.</li><li>2. Be sure wire connections from generator at gas valve terminals are tight and generator is fully inserted into pilot bracket.</li><li>3. Check thermogenerator with millivolt meter. Take reading at "TH-TP" and "TP" terminals of gas valve. Should read 325 millivolts minimum while holding valve knob depressed in pilot position, pilot lit, and ON/OFF switch "OFF". Replace faulty generator if reading is below specified minimum.</li></ol>
	B. Defective valve	<ol style="list-style-type: none"><li>1. Connect the millivolt meter probes to the "TH-TP" and "TP" terminals on the gas valve. Turn knob to pilot position, depress and light pilot light. If meter reading is greater than 325 m.v. after 30 seconds, the pilot generator is good. If pilot does not stay lit, the valve is defective. If the meter reading is less than 325 m.v., the thermogenerator is defective.</li></ol>
	C. Open wire connection in pilot circuit	<ol style="list-style-type: none"><li>1. Check wire continuity and connections in pilot circuit.</li></ol>

## TROUBLE SHOOTING (CONT'D)

SYMPTOM	POSSIBLE CAUSE	CORRECTIVE ACTION
3. Pilot burning, no gas burner, valve knob "ON", "ON/OFF" switch "ON".	A. Damper control lever in closed position	1. Set damper control lever to open position.
	B. "ON/OFF" switch or wires defective	1. Check ON/OFF switch and wires for proper connections. Place jumper wires across terminals at switch-if burner comes on, replace defective switch. If OK, place jumper wires across switch wires at gas valve-if burner comes on, wires are faulty or connections are bad.
	C. Thermo generator may not be generating sufficient millivoltage. (325 m.v.)	1. Re-check symptom #2 2. Pilot flame not physically close enough to thermo-generator.
	D. Defective valve	1. Turn valve knob to "ON", Place ON/OFF switch to "ON" Check with millivolt meter at generator terminals. Millivolt meter should read greater than 100 m.v. If the reading is OK, and the burner does not come on, replace the gas valve.
	E. Plugged burner orifice	1. Check burner orifice for stoppage and remove.
	F. Wall switch or wires defective	1. Follow corrective action in A.1 above; check switch and wiring. Replace where defective.
4. Pilot and Main Burner go out while in operation	A. High Limit Switch is defective or has reached its maximum temperature	1. Allow unit to cool. Then repeat lighting instructions. 2. If above does not allow for ignition, check high limit switch. Place jumper lines across high limit switch. If you can re-ignite the pilot your high limit switch is defective. Replace high limit switch before using.
	B. No L.P. in tank	1. Check L.P. tank. You may be of fuel.
	C. Bad Thermogenerator	Replace if necessary.

## OPERATING GUIDELINES (STP-SPARK TO PILOT MODEL)

Upon completing the gas line connection, a small amount of air will be in the lines. When first lighting the pilot light, it will take a few minutes for the lines to purge themselves of this air. Once the purging is complete, the pilot and burner will light and operate as indicated in the instruction manual. Subsequent lighting of the appliance will not require such purging.

**WARNING: CHILDREN AND ADULTS SHOULD BE ALERTED TO THE HAZARDS OF HIGH SURFACE TEMPERATURE AND SHOULD STAY AWAY TO AVOID BURNS OR CLOTHING IGNITION. YOUNG CHILDREN SHOULD BE CAREFULLY SUPERVISED WHEN THEY ARE IN THE SAME ROOM AS THE APPLIANCE.**

**IMPORTANT: TURN OFF GAS BEFORE SERVICING APPLIANCE. IT IS RECOMMENDED THAT A COMPETENT SERVICE TECHNICIAN PERFORM THESE CHECKUPS AT THE BEGINNING OF EACH HEATING SEASON.**

**WARNING: THE FLOW OF COMBUSTION AND VENTILATION AIR MUST NOT BE OBSTRUCTED.**

When lit for the first time, the appliance will emit a slight odor for an hour or two. This is due to paint and lubricants used in the manufacturing process. The main burner flame characteristics are steady, not lifting or floating. Typically, the top 1/4 inch of the flame sensor should be engulfed in the pilot flame. A periodic check of these characteristics is necessary (Figure 10).

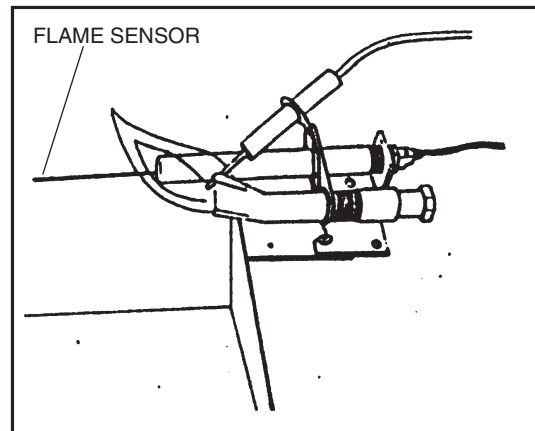

Figure 10

### MAINTENANCE INSTRUCTIONS

**IMPORTANT: THE APPLIANCE AREA MUST BE KEPT CLEAR AND FREE FROM COMBUSTIBLE MATERIALS, GASOLINE AND OTHER FLAMMABLE VAPORS AND LIQUIDS.**

Visually inspect pilot periodically. Brush or blow away any dust or linen accumulations. If pilot orifice is plugged, disassembly may be required to remove any foreign material from orifice or tubing.

Venting system should be periodically examined by a qualified service technician or agency to ensure proper air flow.

## WIRING DIAGRAM (STP-SPARK TO PILOT MODEL)

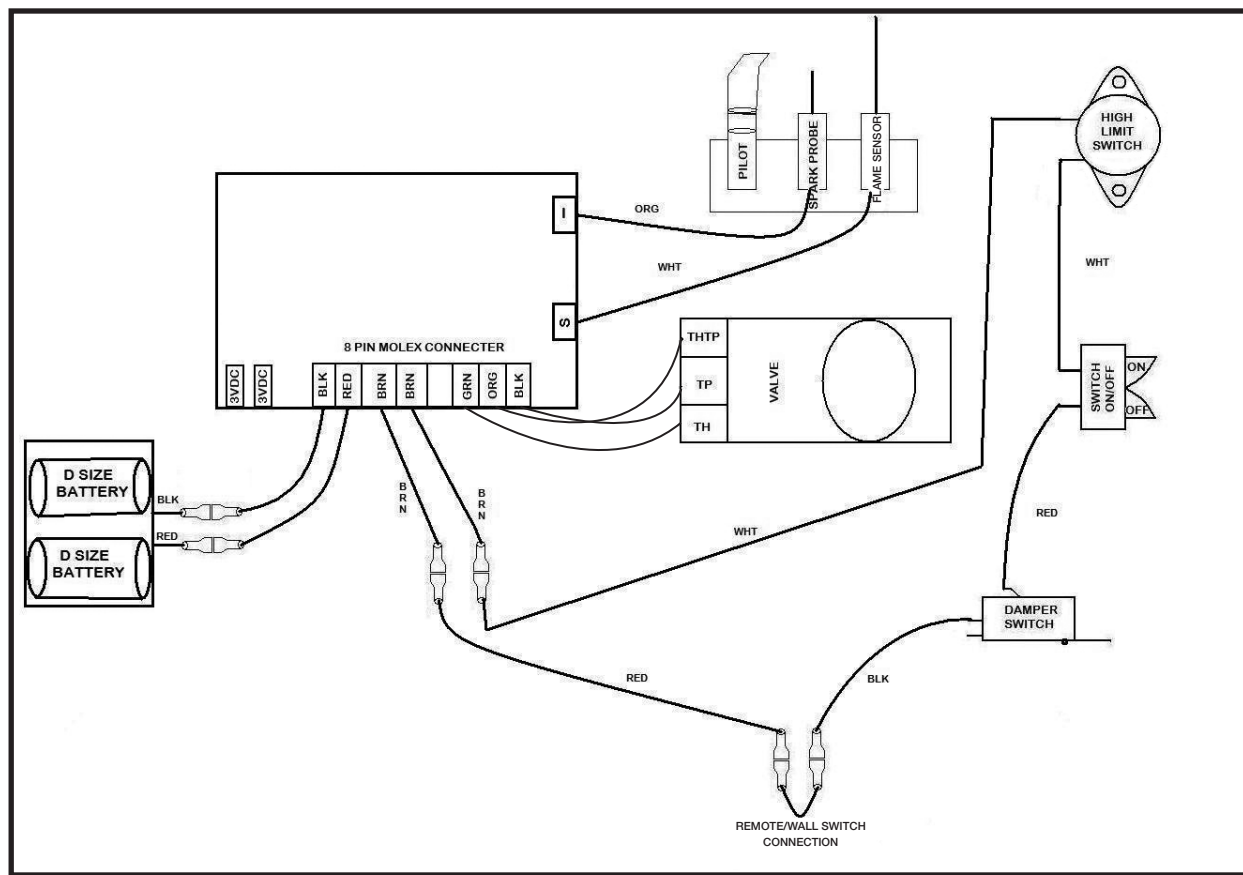

### FOR YOUR SAFETY READ BEFORE LIGHTING

**WARNING:** IF YOU DO NOT FOLLOW THESE INSTRUCTIONS EXACTLY, A FIRE OR EXPLOSION MAY RESULT CAUSING PROPERTY DAMAGE, PERSONAL INJURY OR LOSS OF LIFE.

- A. This appliance is equipped with an ignition device which automatically lights the pilot. Do not light pilot by hand.
- B. BEFORE LIGHTING smell all around the appliance area for gas. Be sure to smell next to the floor because some gas is heavier than air and will settle on the floor.  
**WHAT TO DO IF YOU SMELL GAS:**
  - Do not try to light any appliance
  - Do not touch any electric switch:
  - Do not use any phone in your building.
  - Immediately call your gas supplier from a neighbor's phone. Follow the gas supplier's instructions
- C. Do not use this appliance if any part has been under water. Immediately call a qualified service technician to inspect the appliance and to replace any part of the gas control system which has been under water.

## LIGHTING INSTRUCTIONS ELEC. SPARK TO PILOT

1. "STOP" Read the safety information on page 11.
2. Set the switch to "OFF".
3. Remove batteries from battery pack.
4. This appliance is equipped with an ignition device which automatically lights the burner. Do not try to light the burner by hand.
5. Wait (5) minutes to clear out any gas. Then smell for gas, including near rgw floor. If you smell gas, STOP! Follow "B" in the safety information on page 13. If you don't smell gas, go to next step.
6. Install (2) D batteries in battery pack.
7. Turn ON/OFF rocker switch to "ON".
8. If the appliance will not operate, follow the instructions "To turn Off Gas To Appliance" and call your service technician or gas supplier.

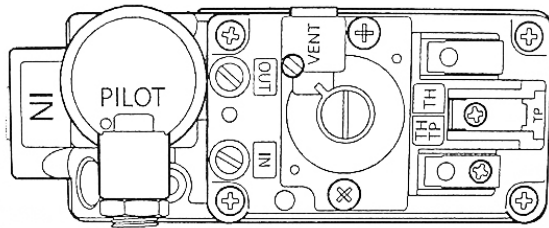

GAS VALVE

**NOTE: DAMPER CONTROL LEVER MUST BE IN THE "OPEN" POSITION TO IGNITE.**

## TO TURN OFF GAS TO APPLIANCE

1. Turn ON/OFF rocker switch to "OFF"
2. Remove batteries from appliance if service is to be performed.

### LPG (PROPANE) WARNING

THE FOLLOWING WARNING APPLIES TO INSTALLATIONS USING L.P. (PROPANE GAS):

**WARNING:** To avoid possible injury, fire and explosion, please read and follow these precautions and all instructions of this appliance before operating. This appliance uses L.P. (Propane) gas which is heavier than air and will remain at the floor level if there is a leak. Before lighting, smell at floor level and/or use other means (such as using a soap solution on all piping and connections, using a gas detector, etc.) to check for gas leaks. NOTE: L.P. (Propane) gas can become odorless and CANNOT always be detected by smell. If you smell gas, detect a gas leak or suspect that a gas leak exists, follow these rules:

1. Get all people out of building.
2. DO NOT light matches. DO NOT turn electric lights or switches on or off in area. DO NOT use an electric fan to remove gas from area. DO NOT use a telephone inside of building.
3. Shut off gas at L.P. tank outside of building.
4. Telephone gas company and fire department. Ask instructions. Before hanging up, give your name, address and phone number. DO NOT go back into building.

If your L.P. tank runs out of fuel, turn off gas at the appliance. After L.P. tank is refilled, appliance must be re-lit according to manufacturer's instructions. If The gas control has been exposed to WATER in any way, DO NOT try to use it. It must be replaced. DO NOT attempt repair on gas control or appliance.

Tampering is DANGEROUS and voids all warranties. Any component that is found to be faulty, must be replaced with an approved component.

## LPG (PROPANE) WARNING (CONT'D)

**IMPORTANT:** Always keep the appliance area clear and free from combustible materials, gasoline and other flammable vapors and liquids.

Never obstruct the flow of combustion and ventilation air. Keep the front of the appliance clear of all obstacles and materials.

To obtain proper operation, it is imperative that the pilot and main burner flame characteristics are steady, not lifting or floating. Typically the top 1/4 Inch of the flame sensor should be engulfed in the pilot flame. (Figure 10)

## TROUBLE SHOOTING (STP-SPARK TO PILOT MODEL)

With proper installation and maintenance, your new Gas Fireplace should provide years of trouble-free service. If you do experience a problem, refer to the trouble shooting guide shown below. This guide will assist a qualified service person in the diagnosis of problems and the corrective action to be taken.

<u>SYMPTOM</u>	<u>POSSIBLE CAUSE</u>	<u>CORRECTIVE ACTION</u>
Ignitor will not spark or pilot will not light	<ol style="list-style-type: none"><li>1. No gas supply or shutoff valve is OFF</li><li>2. Air in gas line</li><li>3. Construction debris clogging pilot orifice</li><li>4. Low gas pressure</li><li>5. Kinked pilot line</li><li>6. Control valve is not opening</li><li>7. No power to unit or ignition module</li><li>8. Damper Closed</li></ol>	<ol style="list-style-type: none"><li>1. Check to see if you have gas supply and that equipment shutoff valve is opened</li><li>2. Repeat lighting procedure several times to purge all air out of lines. If after repeated attempts appliance does not light, call for qualified service and repair</li><li>3. Remove debris and dirt, inspect and clean any other possible obstructions</li><li>4. Contact your gas supplier to check pressure</li><li>5. Have a qualified technician replace pilot line</li><li>6. Replace control valve</li><li>7. Check that main power is on and that all wire connections are made correctly to ignition model (see <i>Wiring Diagram</i>, page 20). Check battery voltage and replace batteries if needed. If battery voltage is good and module does not operate, have module replaced.</li><li>8. Open Damper</li></ol>

## TROUBLE SHOOTING (CONT'D)

<b>SYMPTOM</b>	<b>POSSIBLE CAUSE</b>	<b>CORRECTIVE ACTION</b>
Pilot will not stay lit	<ol style="list-style-type: none"> <li>1. Loose wiring on ignitor wire to ignition module and/or poor ground to ignition module</li> <li>2. Pilot flame too low to sense</li> <li>3. Flame sensor defective</li> </ol>	<ol style="list-style-type: none"> <li>1. Check wiring connection. Refer to wiring diagram (see <i>Wiring Diagram</i>, page 20)</li> <li>2. Clean and adjust pilot burner and check gas supply and inlet pressure to unit <i>Note: Have a qualified technician replace pilot assembly if broken or corroded</i></li> <li>3. Replace flame sensor</li> </ol>
Frequent pilot outage	<ol style="list-style-type: none"> <li>1. Pilot flame may be too low, causing safety pilot to “drop out”</li> <li>2. Improper venting or excessive blockage</li> </ol>	<ol style="list-style-type: none"> <li>1. Clean and adjust pilot flame for maximum flame impingement on flame probe</li> <li>2. Have vent system inspected, including termination cap. Remove any restriction or obstruction</li> </ol>
Slight smoke or order during initial operation	<ol style="list-style-type: none"> <li>1. Residues from manufacturing process</li> </ol>	<ol style="list-style-type: none"> <li>1. Problem will stop after a few hours of operation</li> </ol>
Pilot and Main Burner go out while in operation	<ol style="list-style-type: none"> <li>1. High Limit Switch is defective or has reached its maximum temperature</li> <li>3. No L.P. in tank</li> </ol>	<ol style="list-style-type: none"> <li>1. Allow unit to cool. Then repeat lighting instructions.</li> <li>2. If above does not allow for ignition, check high limit switch. Place jumper lines across high limit switch. If you can re-ignite the pilot your high limit switch is defective. Replace high limit switch before using</li> <li>3. Check L.P. tank. You may be out of fuel</li> </ol>

## REPLACEMENT PARTS

ITEM	PART #	DESCRIPTION	ITEM	PART #	DESCRIPTION
1	TV-101	Gas Valve - N/G	17	TV-117	Middle Left Log
2	TV-102	Gas Valve - LP	18	TV-118	Middle Right Log
3	TV-103	"1/4" Pilot Line"	19	TV-119	Top Left Log
4	TV-104	"3/8" Burner Line"	20	TV-120	Top Right Log
5	TV-105	Piezo Ignitor	21	TV-121	Ember Material
6	TV-106	On/Off Switch	22	TV-122	Vermiculite
7	TV-107	Pilot Assembly - Nat.	23	TV-123	Volcanic Rock
8	TV-108	Pilot Assembly - LP	24	TV-124	Temp Limit Switch
9	TV-109	Thermopile	25	TV-125	Damper Switch
10	TV-110	Pilot Assembly Bracket	26	TV-126	Battery Pack (STP Model)
11	TV-111	Burner Orifice NAT	27	TV-127	Gas Valve-N/G (STP Model)
12	TV-112	Burner Orifice LP	28	TV-128	Gas Valve-LP (STP Model)
13	TV-113	Burner Pan Assembly	29	TV-129	Ignition Module (STP Model)
14	TV-114	Log Grate	30	TV-130	Pilot Assembly - Nat. (STP Model)
15	TV-115	Bottom Front Logs	31	TV-131	Pilot Assembly - LP (STP Model)
16	TV-116	Bottom Rear Log	32	TV-132	Flame Sensor

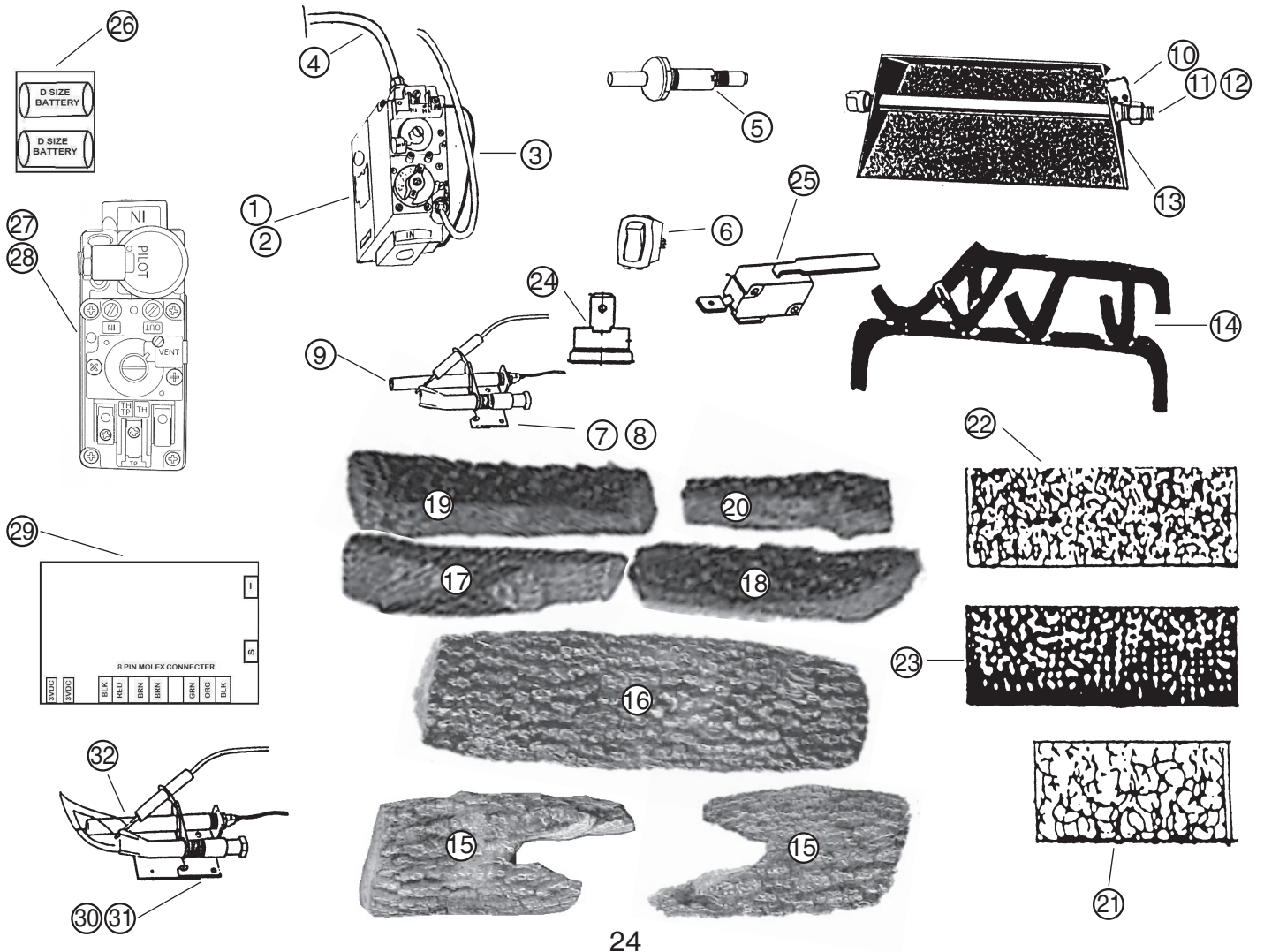

## **TWO YEAR LIMITED WARRANTY**

THIS WARRANTY IS LIMITED TO TOP-VENT GAS FIREPLACES MANUFACTURED AND ASSEMBLED BY GOLDEN BLOUNT.

IF GOLDEN BLOUNT FINDS THAT ANY PART OR PORTION OF THE FIREPLACE COVERED BY THIS WARRANTY IS DEFECTIVE IN MATERIAL OR WORKMANSHIP UNDER NORMAL USE AND SERVICE AS DESCRIBED IN THE INSTALLATION AND OPERATING INSTRUCTIONS, GOLDEN BLOUNT WILL TAKE THE FOLLOWING ACTIONS:

1. WITHIN THE FIRST YEAR FROM THE DATE OF INSTALLATION, GOLDEN BLOUNT SHALL, AT ITS OPTION REPLACE OR REPAIR ANY SUCH DEFECT IN MATERIAL OR WORKMANSHIP, AT GOLDEN BLOUNT'S EXPENSE, INCLUDING A REASONABLE LABOR ALLOWANCE AS DETERMINED BY GOLDEN BLOUNT. GOLDEN BLOUNT SHALL NOT BE RESPONSIBLE FOR ANY OTHER LABOR COSTS, OR EXPENSES, INCLUDING INDIRECT, INCIDENTAL OR CONSEQUENTIAL DAMAGES.
2. DURING THE SECOND YEAR AFTER THE DATE OF INSTALLATION, GOLDEN BLOUNT SHALL SUPPLY REPLACEMENT PARTS AT THE CURRENT WHOLESALE PRICE, BUT GOLDEN BLOUNT SHALL NOT BE RESPONSIBLE FOR ANY LABOR, TRANSPORTATION, OR THE INDIRECT, INCIDENTAL, OR CONSEQUENTIAL DAMAGES.
3. ALL FACTORY OPTIONAL COMPONENTS OR ACCESSORIES FOUND TO BE DEFECTIVE WILL BE REPAIRED OR REPLACED WITHOUT CHARGE DURING THE FIRST YEAR AFTER INSTALLATION.

GOLDEN BLOUNT MAY DISCHARGE ITS ENTIRE WARRANTY LIABILITY BY REFUNDING THE PRICE OF THE PRODUCT.

PRODUCTS MADE BY OTHER MANUFACTURERS, SOLD WITH THE FIREPLACE OR THEREAFTER ARE NOT COVERED BY THIS LIMITED WARRANTY. THE USE OF OTHER UNAUTHORIZED COMPONENTS WILL MAKE THIS WARRANTY NULL AND VOID.

THIS LIMITED WARRANTY WILL BE VOID IF THE APPLIANCE IS NOT INSTALLED BY A QUALIFIED INSTALLER AND ACCORDING TO THE INSTALLATION INSTRUCTIONS. THE LIMITED WARRANTY ALSO IS VOID IF THE FIREPLACE IS NOT OPERATED, AT ALL TIMES, ACCORDING TO THE OPERATING INSTRUCTIONS FURNISHED.

SOME STATES DO NOT ALLOW EXCLUSION OF INCIDENTAL OR CONSEQUENTIAL DAMAGES OR LIMITS ON THE DURATION OF IMPLIED WARRANTIES SO THESE LIMITATIONS MAY NOT APPLY TO YOU.

GOLDEN BLOUNT RESERVES THE RIGHT TO INVESTIGATE ANY AND ALL CLAIMS AGAINST THIS WARRANTY AND TO DECIDE ON THE METHOD OF SETTLEMENT.

GOLDEN BLOUNT IS NOT RESPONSIBLE FOR WARRANTY WORK COMPLETED WITHOUT OBTAINING GOLDEN BLOUNT'S CONSENT. GOLDEN BLOUNT EMPLOYEES AND DEALERS HAVE NO RIGHT TO ALTER THIS WRITTEN WARRANTY.

### **WARRANTY INFORMATION**

PLEASE BE ABLE TO PROVIDE THE FOLLOWING INFORMATION WHEN COMMUNICATING WITH GOLDEN BLOUNT OR ITS DEALERS OR DISTRIBUTORS REGARDING SERVICE UNDER THIS WARRANTY.

MODEL NO.  
SERIAL NO.  
DATE OF PURCHASE

Golden Blount  
4301 Westgrove Dr.  
Addison, TX. 75001  
(972) 250-3113